

Wallgate Anti-Ligature, Anti-Vandal S/Surface Ravehall Basin NTH-White

PRODUCT CODES

- WHB-181-NB-AUS



WaterMark
AS/NZS 3718 Lic. 023196
Pro-Switch Pty Ltd



SPECIFICATIONS

- Anti-Ligature design
- Highly Robust
- Highly polished finish for ease of cleaning
- Easily renewable surface without a gel coat layer

IMPORTANT: To achieve WELS 6 Star Rating, this product must be installed with provided flow regulator.

WARNINGS: Special attentions to be paid on notes, photos, images, or drawings of assembly steps marked with the warning symbol.



TECHNICAL DATA

Nominal Flow Rate (LPM)	4.28
Finish	Solid Surface

NOTE: Galvin Engineering continually strive to improve their products. Specifications may change without notice.

DIMENSIONS

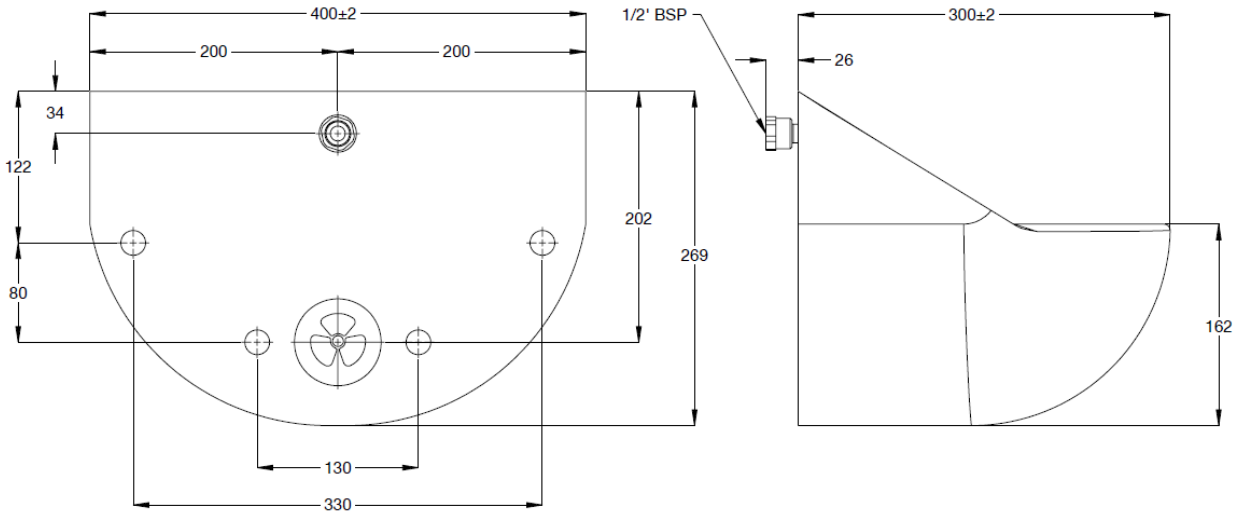

INSTALLATION

INSTALLATION COMPLIANCE: Galvin Engineering products must be installed in accordance with these installation instructions and in accordance with AS/NZS 3500, the PCA and your local regulatory requirements. Water and/or electrical supply conditions must also comply to the applicable national and/or state standards. Failing to comply with these provisions shall void the product warranty and may affect the performance of the product.

Refer attached drawings for installation.

⚠️ NOTE: To achieve WELS 6 Star Rating, this product must be installed with provided flow regulator.

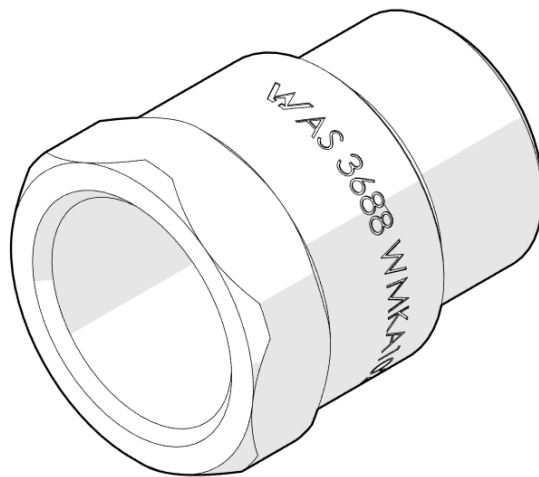

Figure 1

WARRANTY

The warranty set forth herein is given expressly and is the only warranty given by the Galvin Engineering Pty Ltd. With respect to the product, Galvin Engineering Pty Ltd makes no other warranties, express or implied. Galvin Engineering Pty. Ltd. hereby specifically disclaims all other warranties, express or implied, including but not limited to the implied warranties of merchantability and fitness for a particular purpose.

Galvin Engineering Pty Ltd products are covered under our manufacturer’s warranty available for download from www.galvinengineering.com.au Galvin Engineering Pty Ltd expressly warrants that the product is free from operational defects in workmanship and materials for the warranty period as shown on the schedule in the manufacturer’s warranty. During the warranty period, Galvin Engineering will replace or repair any defective products manufactured by Galvin Engineering without charge, so long as the terms of the Manufacturer’s warranty are complied with.

The remedy described in the first paragraph of this warranty shall constitute the sole and exclusive remedy for breach of warranty, and Galvin Engineering Pty Ltd shall not be responsible for any incidental, special or consequential damages, including without limitation, lost profits or the cost of repairing or replacing other property which is damaged if this product does not work properly, other costs resulting from labour charges, delays, vandalism, negligence, fouling caused by foreign material, damage from adverse water conditions, chemical, electrical or any other circumstances over which Galvin Engineering has no control. This warranty shall be invalidated by any abuse, misuse, misapplication, improper installation or improper maintenance or alteration of the product.

Within Australia: 1300 514 074 Outside Australia: P: +61 (0)8 9338 2344

F: +61 (0)8 9338 2340

sales@galvinengineering.com.au

www.galvinengineering.com.au

ABN: 78 008 719 382

PERTH | SYDNEY | MELBOURNE | BRISBANE | ADELAIDE

